

Making Places

Linda Fleming and Michael Moore

July 12 - September 22, 2013



Making Places is at once a retrospective, a new commission, a 3D instruction manual, and an intimate examination of what it takes to develop an art-driven life.

Linda Fleming and **Michael Moore** have been married for decades; their life together is a pastiche of homes built, places cultivated, practices evolved, dogs loved, friends lost, meals shared, and first-and-foremost, art produced. The exhibition features custom-made spaces, collected objects, designed audience experiences, as well as the couple's remarkable paintings, drawings and sculptures.

CCA |

1050 Old Pecos Trail
<http://ccasantafe.org>

Santa Fe, New Mexico
OPEN: Th-Sun, 12-5pm

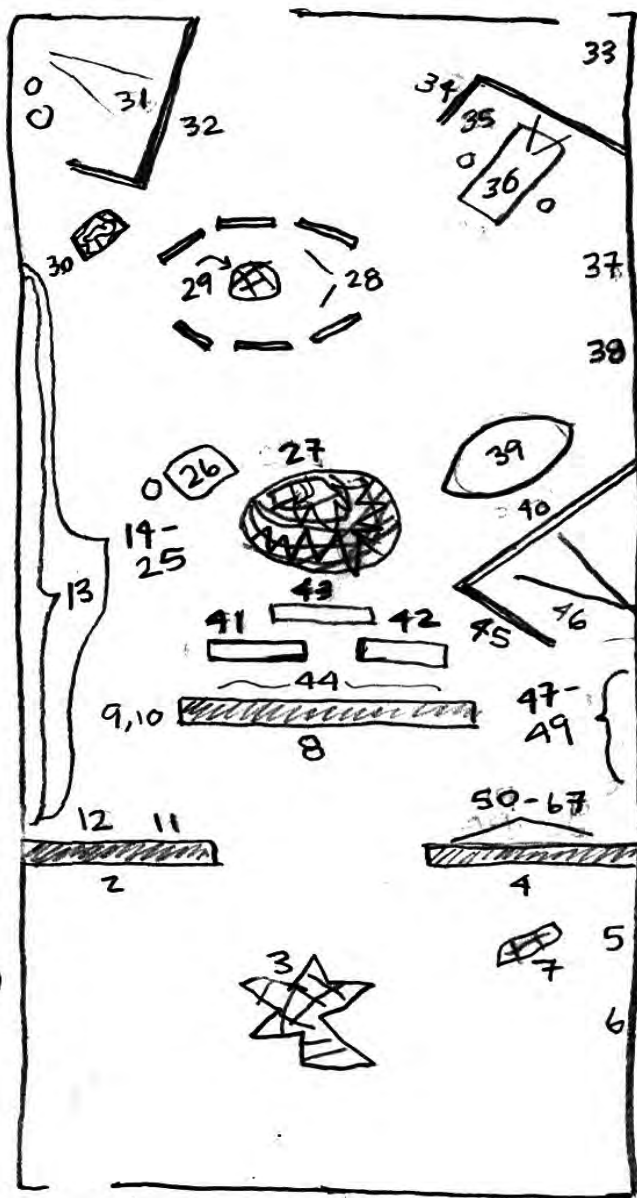

Many works are for sale, please inquire at the front desk for a price list. All works are denoted by LF for Linda Fleming or MM for Michael Moore.

1. LF: *Lightning Ball*, 2013
powder coated steel, 72 x 40 inches

2. LF: *Folds*, 2013
powder coated steel, 64 x 77 inches

3. LF: *Helios*, 2011
powder coated steel, 100 x 110 x 56 inches

4. MM: *Burnt Rock/Indian Rock*, 1999
acrylic on canvas, 72 x 114 inches

5. MM: *Untitled [Benicia, 2012]*, 2012
acrylic on canvas, 57 x 57 inches

6. MM: *Disappointment Lake*, 2001-2
acrylic on canvas, 60 x 72 inches

7. LF: *Gem*, 2013
powder coated steel, 24 x 96 x 44 inches

8. MM: *The Weather Channel*, 2012
Watercolor, 8 x 46 inches

9. MM: *Owyhee Truck*, 2010
photo collage, 14 x 11.5 inches

10. MM: *Nevada Tanks*, 2010
photo collage, 14 x 11.5 inches

11. MM: *Sunday in America*, 1973
acrylic on canvas, 48 x 48 inches

12. MM: *Some Are Missed*, 1974
acrylic on canvas, 48 x 48 inches

13. MM: *Auto Biographies 1958 – present (1973-2013)*, 2013
digital prints, from original ink drawings, ed. of 4

14. MM: *Another Enigma of the Sheldon Range*, 1975
acrylic on canvas, 60 x 60 inches

15. MM: *Duferrena Dece 3 [Engine Block Rock]*, 1979
acrylic on canvas, 59 x 59 inches

16. MM: *Khumbu 4 Overpaint*, 1978
acrylic on canvas, 57 x 57 inches

17. MM: *Valley Painting*, 1986
acrylic on canvas, 48 x 48 inches

18. MM: *Fire By Water 1*, 1989
acrylic on canvas, 60 x 48 inches

19. MM: *"Outside,"* 1995
acrylic on canvas, 48 x 48 inches

20. MM: *West Marin A Few Days Later [California Pastoral]*, 1986-96
acrylic on canvas, 48 x 60 inches

21. MM: *Some Nevada Nocturnes*, 1998
acrylic on canvas, 48 x 48 inches

22. MM: *John's Coal Train*, 2003
acrylic on canvas, 48 x 48 inches

23. MM: *San Luis*, 2008
acrylic on canvas, 48 x 60 inches

24. MM: *Easter Morning Okinawa 1945, 2007-08*
acrylic on canvas, 60 x 60 inches

25. MM: *House Threatened By Noodles*, 2012
acrylic on canvas, 57 x 57 inches

26. LF: *All My Studios*, 2013
chair, stumps, sound; 20 minutes
27. LF: *Dark Matter*, 2003
Rubber, 116 x 172 inches
28. LF: various maquettes, 1978-2013
paper, wood, cast bronze, foam core, and cut felt
* many have been realized on a larger scale
29. LF: *Ice Crystal*, 2013
powder coated steel, stainless steel; 36 x 36 x 48 inches
30. LF: *Smoke Creek Topography*, 2006
felt and steel, 50 x 46 x 35 inches
31. LF: *Creek Walk*, 2013
digital video, 14 minutes
32. LF: *Portal*, 2010
steel and chrome, 96 x 75 inches
33. MM: *The Agrarian Aquarian Aquarium*,
acrylic, aluminum paint on canvas, 56 x 56 inches
34. LF: *Shimmer*, 2011
steel and chrome, 42 x 22 inches
35. Stephen Chandler
Wall Spring Interior
inkjet print, 11.25 x 12.75 inches
36. MM: Slides, 1978-1999
* please ask gallery attendant for assistance in
changing slide reels
37. MM: *Carnac/Karnac*, 1965-66
acrylic on canvas, 94 x 47 inches
38. LF: *Shell Goblet*, 1989
graphite on rag paper, 92 x 64 inches
39. Benicia, CA kitchen table, chairs, and candelabra
40. LF: *Greentime*, 2004
graphite, colored pencil on rag paper, 65 x 56 inches
41. MM: vitrine #1 of journals
left to right, facing front: *Maps*, 1964; *DMT*, 1967;
The Notebooks of Bardoff Ouspensky, 1966-68
left to right, facing back: *Fulham Power Station for
Sale*, 1981; *Summer*, 1982; *Room Temperature and
Other Drawings*, 1983; *Eccentric Drawings*, 1984;
Summer, 1984; *Begins*, 1985; *And to the End of the
Known World*, 1986; *And So On*, 1987-1994; *A Black
House Book*, 1990-91
42. MM: vitrine #2 of journals
left to right, facing front: *It's Not German*, 1968;
Japón, 1974; *World Book Encyclopedia of the
Greater L.A. Basin*, 1968; *Black Book*, 1969;
Boog, 1969; *The Scribble-In Book*, 1969-71.
left to right, facing back: *Art Bandits Beyond
Plush*, 1972; *It's All Ways A Live*, 1972-74; *Art
Depart: Paintings Sold*, 1973; *Book 7194-2*,
1974(79); *August 27*, 1979, 1979-1984
43. MM: vitrine #3 of journals
left to right, facing front: *'74 Dodge Van 4x4*,
1992-93; *San Francisco California Saturday*,
1993; *Wall Spg Tlrs*, 1996; *We'll Mine the Other
Planets Later*, 1996-97; *Wall Spg Tlrs*, 1997;
NYC 1098, 1998-2001
left to right, facing back: *Building a Building*,
1999, 2001; *The First Moleskine Book*, 2002-
2004; *Let's Do a Few Lines*, 2003; *Mapping a
History*, 2004; *The Second Moleskine Book*,
2004-05; *How Good is That? (Closed Under
Rock)*, 2005-09; Nikon camera lost six years up
Dry Creek which Christine found; *Book From
Christine Christmas 2008*, 2009-2010; *Benicia
Bay Book*, 2002
44. Wall of ephemera and influences including:
MM: *Owyhee Tanks*, 2010
photo collage, 14 x 11.5 inches

MM: *Halogeton Flat Sunrise*, 2009
photo collage, 14 x 11.5 inches

LF: model of Libre house, 2008
Balsa wood
45. LF: *Dome*, 2008
graphite, colored pencil on rag paper, 57 x 67 inches
46. LF: *Making Places*, 2013
digital video, 25 minutes
* soundtrack for sale at front desk
47. LF: *Thoughts – Playa*, 2012
photograph, 43 x 57 inches
48. LF: *Thoughts – Piñon*, 2012
photo, 43 x 51 inches
49. LF: *Thoughts – Cliffs*, 2012
photograph, 43 x 51 inches
- 50-67. LF: Drawings, 1967-1969
gouache, colored pencil, ink, mylar on paper
sizes vary

Linda Fleming's drawings and sculptures create places of shadow and light. She has exhibited widely throughout the United States and her works are in international collections in Moscow, Russia; Bagdad, Iraq; Sydney, Australia; and Seoul, Korea as well as the U.S. Her public installations include: the International Quilt Study Center, Lincoln, Nebraska; the Berkeley Art Museum; Oakland Museum; Cantor Museum of Art, Stanford University; and Nevada Museum of Art. Fleming's work has been reviewed in numerous periodicals including: Art in America, Sculpture magazine, and the New York Times. Currently, she is a Professor of Fine Arts in Sculpture and Graduate Studies at California College of the Arts in San Francisco. Fleming was honored as CCA's Distinguished Faculty and has been awarded grants by the Pollock-Krasner Foundation, the Adolph and Esther Gottlieb Foundation, Art Matters, and the Athena Foundation.

Michael S. Moore was born in Los Angeles California and drew from an early age. He graduated from Stanford University and left the Yale MFA program after a year to paint, showing frequently around the Bay Area, Los Angeles and beyond. His works are in many private collections as well as numerous corporate collections and institutions such as Stanford University, Mills College, OMCA, SFMOMA, the Oats Park Art Center in Fallon, Nevada, and others.



Special thanks to: California College of the Arts, Flora Clancy, Luz Fleming and Christine Howard Sandoval, William Kirk Moore Photography, Ed and Sara Groendyke, David and Abby Smith Rumsey, and Anonymous. Linda Fleming's work is made available by Brian Gross Fine Art, San Francisco; and Robischon Gallery, Denver.